

※ 尺寸/Dimensions 单位/Unit : (mm)

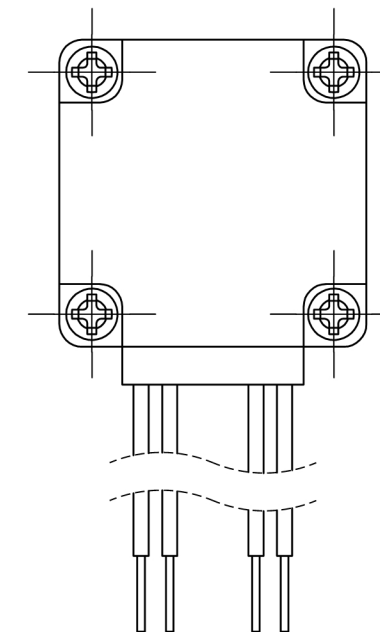
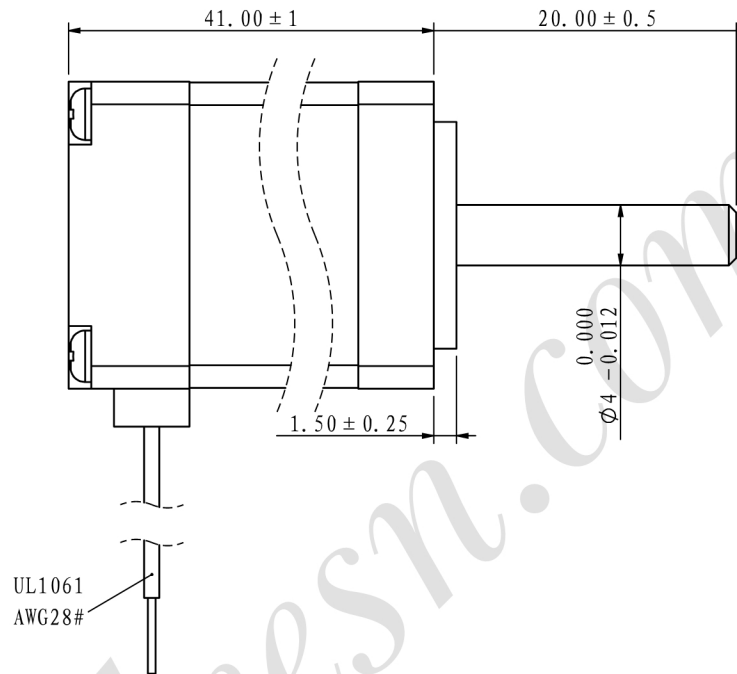
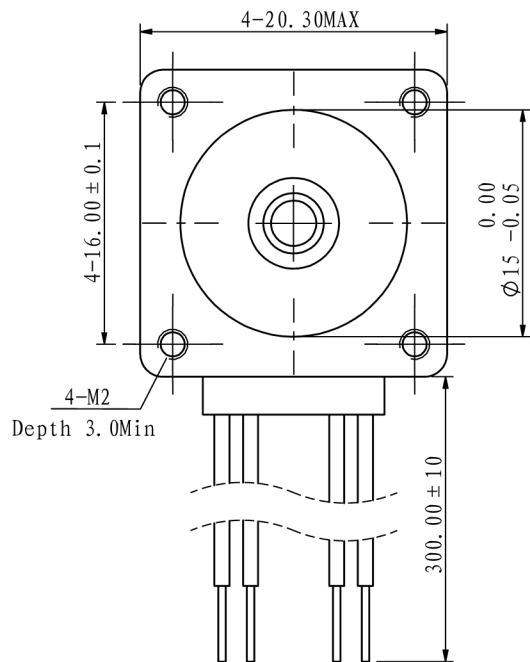

※ 电机规格/Motor Specification

相数/No. of phase	2 相/phase
步距角/Basic step angle	1.8°
步距角误差(空载)Positional accuracy(no-load)	±0.09° 以下/Max
额定电流/Rated current	0.8 A
保持扭矩/Holding torque	0.05 N.m
相电阻/Phase resistance	5 ±10% ohm(20°C)
相电感/Phase inductance	3.1 ±20% mH(1KHz)
转子惯量/Rotor inertia	≈2.9 g.cm <sup>2</sup>
重量/Weight	≈ 60.00 g
绝缘耐压/Dielectric strength	500V A.C
绝缘电阻/Insulation resistance	100MΩ以上/MIN
绝缘等级/Insulation class	B
使用温度范围/Operation ambient temperature	0°C~+50°C
使用湿度范围/Operation ambient humidity	20%RH~90%RH
使用温度范围/Storage ambient temperature	-20°C~+70°C
保存湿度范围/Storage ambient humidity	15%RH~95%RH

※ 接线图/Wiring diagram

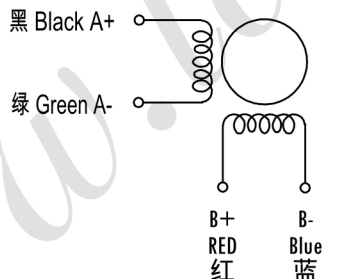

第一角画法  
Frist Angel View

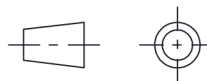

※ 励磁顺序 (2相励磁)

Phase sequence(2 phase exciting)

Step	A	A-	B	B-
1	+	+	-	-
2	-	+	+	-
3	-	-	+	+
4	+	-	-	+
5	+	+	-	-

CW (Clockwise) and CCW (Counter-clockwise) directions are indicated.

※ 铭牌内容

Label discription

名称/Name	型号/Model	LS20A005-A2Y08
两相步进电机 2 phase stepping motor	品号/Product No.	
公差 Tolerance	比例 Scale	页码 Sheet
±0.3	2:1	1/1
客户型号 Customer model	客户品号 Customer Product No.	
<b>深圳市立三机电有限公司</b> <b>Shenzhen Lisan Machinery &amp; Electric Co., Ltd</b>		

版本/Rev	日期/Date	变更内容/Revision record
制图 Drawn	2019/11/29	设计 Design
审核 Checked		批准 Approved